

# BRACKET BH10M

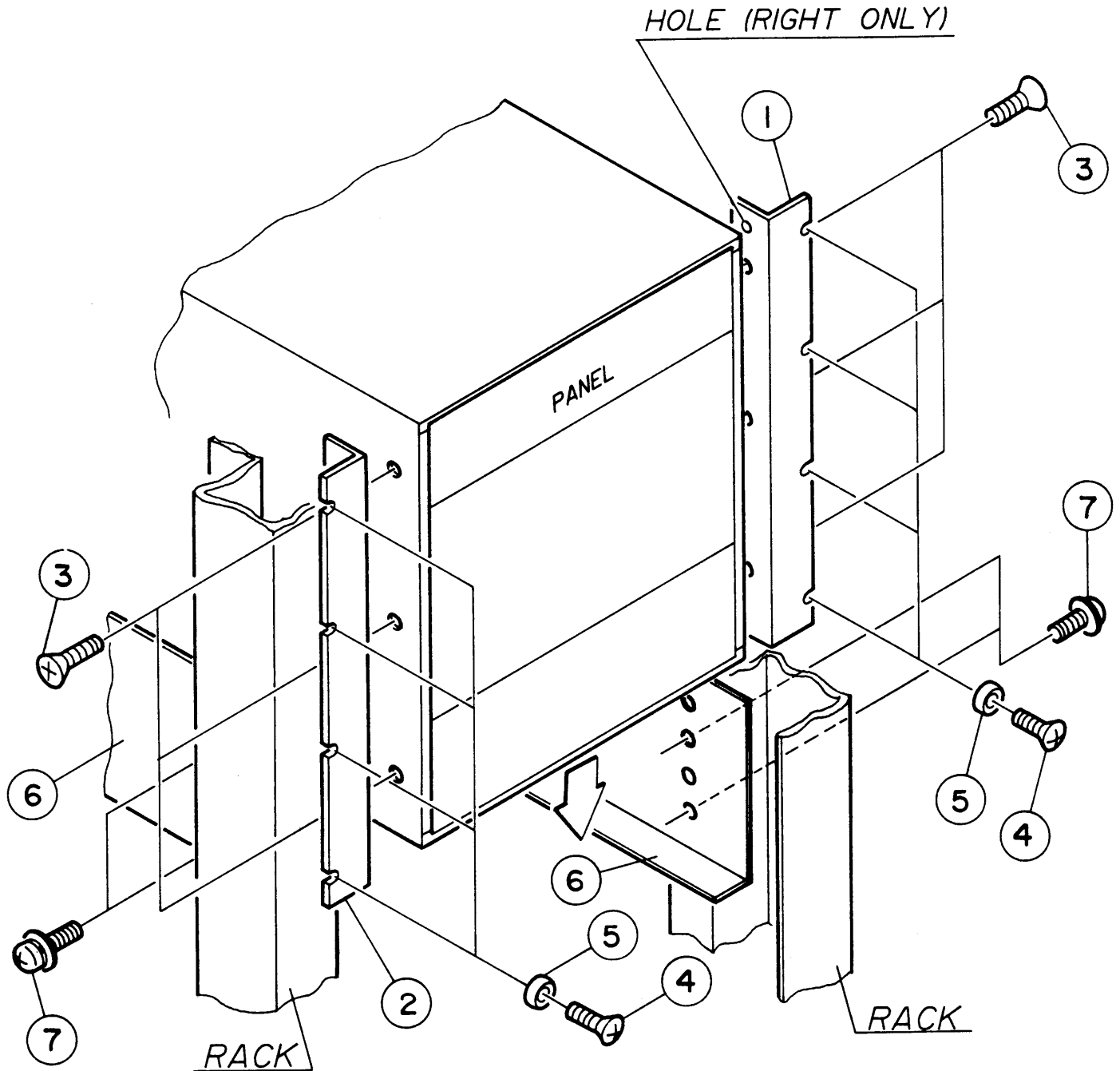

NO.	DESCRIPTION	QTY	CODE NO.
1	BRACKET BH10M RIGHT	1	D3-988-301
2	BRACKET BH10M LEFT	1	D3-988-302
3	SCREW, FLAT HEAD M5x0.8x20 S-ZMC2	6	M2-001-451
4	SCREW, OVAL HEAD M5x0.8x14 B-NI	8	M2-002-091
5	FINISHING WASHER 5CW	8	M5-003-031
6	RAIL FOR EXTRA WEIGHT	2	D4-988-701
7	SCREW WITH SW, PW M5x0.8x10 S-ZN	8	M3-012-131